

APPENDIX D

UTILITY CUT REPAIR GUIDELINES AND SPECIFICATIONS FOR THE PERMITTING PROCESS

D.1 OVERVIEW OF UTILITY CUT ISSUES

In recent years, utility owners have increasingly chosen to take their distribution networks underground. According to a 1997 report published by APWA, "Managing Utility Cuts",

"The issues surrounding the management of utility cuts are as varied as the cuts are numerous. As the demand for greater access to the right of way increases, so will the need for better coordination of multi-agency schedules and a higher level of accountability for employing less intrusive, more durable and cost efficient methods for making utility cuts."

This has certainly been the experience of Nashville.

As a result, several cities across the nation have undertaken projects to make fair and uniform assessment of the damage due to utility cuts, and to assess an appropriate fee schedule to recover the damages. Additionally, research has been conducted to establish a more "engineered" approach to repairing the cuts. In other words, agencies are adopting a "do it right the first time" specification.

This study researched current practices and reviewed other agency specifications, then used these findings to develop a guide to utility cut management. The findings and recommendations are presented in three parts:

- Current Practices within MPW
- Process Used to Identify Level of Utility Degradation
- Specifications and Construction Guidelines for Trench Repair

D.2 CURRENT PRACTICES IN MPW

In 1997, MPW amended Chapter 13.20, Excavations and Obstructions, of the Metropolitan Code of Laws in an attempt to increase the service life of the MPW's pavement network. This amendment, enacted through Ordinance 97-785, Excavations and Obstructions, now requires that any pavement surface removed or damaged as a result of an excavation must be replaced by, and at the expense of, the person or organization responsible for making the excavation. In addition, a reputable paving contractor must perform the repair in accordance with the requirements and specifications of the Department, and the repair can only be performed in the presence of a Department inspector.

The applicable specification for pavement repair on MPW roads and streets is contained in Section 02575, Pavement Repair, of the MPW Standards. Specifically, Paragraph 3.9 stipulates that full lane or roadway width milling and/or paving is required where successive or continuous excavations are planned so as not to "checkerboard" the repair and to provide a

smooth riding surface. The length of full width milling and/or paving is to be from manhole to manhole centerline from the first excavation point to the last. In addition, if the excavation is within 300 feet of an intersection, the repair limits are to be extended to the radius point of the intersection.

According to Section 13.20.030.D.1 of the Metro Code, an excavation permit is required for each separate excavation. A single excavation is defined as having a maximum area of 6 square yards or a maximum length of 33 ft. Excavations having an area or length greater than these limits must be separated into two or more excavations, each requiring its own permit. In addition to the permit fee, an excavation made in a pavement surface less than 5 years old is assessed a fee of \$500 plus 20% of the average cost to repair the excavation according to MPW specifications

In 2001, the Department issued a contract to IMS/Terracon, a pavement management consultant, to study the impact of utility cuts on the service life of MPW pavements and to develop a fee schedule for excavation permits that would prorate the cost of repairing excavations among the permit holders who damaged the surface (Development of a Street Damage Restoration Fee Schedule for the Metropolitan Government of Nashville and Davidson County, Terracon, February 2001). The fee schedule was designed to recoup the cost of milling and paving an entire block once the surface condition deteriorated to a specified level. The fee schedule was also weighted based on the age of the surface, with higher fees charged for excavations in newer pavements. This fee schedule, however, was never implemented.

D.2.1 Specification Issues

The current specification for pavement repair, Section 02575, specifies high-quality materials and procedures. The IMS/Terracon study concluded that repairs made in accordance with this specification were actually stronger than the surrounding pavement. The major concern expressed by the Department staff with this specification lies in the lack of enforcement of Paragraph 3.9. Utility companies are not being required to mill and pave full width between successive cuts or along continuous cuts or between cuts and to intersections 300 feet or less in proximity.

Part of the problem lies in the wording of this provision. Rarely does a utility plan for and request permits for multiple cuts within the same block. The most common scenario involves a request for a single cut within a block that already contains one or more cuts; there is no provision to have the utilities mill and/or pave full width between the proposed cut and an existing cut. Two options were presented in the Terracon report to MPW to address the ride quality and aesthetics issues posed by utility cuts.

Option 1 is to amend Paragraph 3.9 of the Pavement Repair specification to require full width milling and paving between the proposed cut and any existing cut within 10 feet. The suggested 10-foot length will prevent numerous adjacent small repairs that deteriorate ride quality, appearance and overall performance. Of course, this option is viable only if it is enforced, but nearly 100 percent compliance should be achievable if the issuance of future permits to a given utility is tied to their past compliance with the specification.

Option 2 is to implement the fee schedule proposed in the IMS/Terracon report. On the average, this option would generate sufficient funds to repave an entire block once 15 percent of the block's surface area is affected by a utility cut repair. The proposed fees are easily calculated

from the information contained in the permit application and the pavement management system database, and the fees should be easy to collect if issuance of the permit is tied to payment of the fees. The higher fees will be cheaper for the utilities than the extensive paving required by Option 1. The significantly higher permit fees will likely be strongly opposed by the utilities.

Option 1 is recommended because it offers the path of least resistance in meeting the goal of smoother riding pavement surfaces. The specification is already in place, so a small amendment should not be too difficult to accomplish. The amendment should be accomplished prior to the start of enforcement. The utilities likely would voice opposition to the sudden enforcement of the current specification, so opposition to enforcement of the amended specification can certainly be expected.

D.2.2 Performance of Utility Cut Repairs

Utility cuts, like other patches, cause damage that reduces the level of service of the street. This is not a new concept, but one that pavement engineers have dealt with since cuts in the pavement right-of-way to bury utilities have been allowed. The surface condition rating method selected by MPW, ASTM D6433, includes a serviceability deduct value for the presence of a utility cut. This deduct value is comparable in severity to the deduct values assigned for longitudinal and transverse cracking. The problem is not one of "does the cut damage the pavement," but rather, "how can the impacts be quantified as to costs and how do these translate into reasonable and defensible fees?"

In 2002, the Construction Practices Subcommittee of the APWA was assigned to research available documents related to pavement degradation caused by utility cuts. A summary of the major findings of their literature review follows:

- Factors influencing the performance of a patch include the pavement material, soil conditions, climate, traffic and repair techniques. These roughly correlate with the same factors influencing the life of a new pavement.
- Poor construction techniques, such as rocking the jackhammer while cutting the boundary of the patch, can damage the area adjacent to the cut and further degrade the patch and surrounding pavement. Studies showed this zone of influence to be 1.5 to 6 feet beyond the patch.
- Pavement cut repairs made using quality materials and sound engineering and construction techniques tend to perform as well as the surrounding pavement.
- Poor performance of the patch tends to be a result of inadequate compaction of the materials, insufficient thickness of materials, poor quality of materials, and damage to the side of the cut.
- Most of the reports included a cost analysis associated with the cuts ranging from \$2 per square yard to \$540 per square yard.
- The estimated reduction in pavement life due to a utility cut was found to be from 20 to 56% of the original life of the pavement.

These observations are consistent with the findings of the Terracon report and with other studies such as the Salt Lake City report (*Public Works*, April 2002) where structural testing was used to quantify the degradation caused by a utility cut. The Terracon report suggested the unit

rate for pavement overlay was \$21.67 per square yard. Further it was determined that the fees for recovery should be prorated due to the age of the pavement, and that new pavements should have the highest rate of recovery. A full table of fees is found in the Terracon report.

The Salt Lake City report used deflection tests with an FWD (Falling Weight Deflectometer) to prove that the zone of influence or damage beyond the visual limit of the trench was at least 2 feet. It was suggested that a “T” patch (replaces surface course at least 2 feet beyond trench boundaries) be used to compensate for this damage. Additional suggestions were made for selecting the cut boundaries. Other somewhat intangible costs were discussed, but no consensus seemed to exist for recovery of these costs. They include traffic disruption, safety of repair personnel, emergency vehicle response times due to rough patches and others.

The findings of the report prepared by Terracon are consistent with those of other agencies, and it is recommended that these findings be used in developing MPW's specification and permit fee policy.

D.3 CONSTRUCTION GUIDELINES FOR TRENCH REPAIR

Chapter 13.20 of the Metro Code has been cited as a model by the APWA and referenced in many of the articles studied for this report. Therefore, it is recommended that the current code be modified to include recent improvements in practice being used by other municipalities. The requirement for patch awareness and repair training and a specification for the “T” patch are also submitted for adoption. The recommended modifications are summarized as follows:

D.3.1 Requirements for Training

Recognizing that education and awareness by the utility companies as to the impact of their cuts on pavement life and the quality of the community is needed, it is suggested that representatives from utility companies and contractors be required to attend a ½-day workshop on patching utility cuts. This workshop would cover the impacts of cuts on street performance and the associated economic burden on the community as well as proper utility cut procedures. The workshop should be based on the Strategic Highway Research Program manuals of practice and include the rating tree procedure. The presence of a workshop graduate would be required to perform a utility cut or utility cut repair.

D.3.2 T-Patches

T-Patches are pavement cuts made outside the trench boundaries so there is not a continuous vertical shear plane from the edge of the trench to the pavement surface. Research shows that the zone of influence is at least 2 feet from the edge of the trench. To take advantage of the layering effects of a flexible pavement, the compacted base and the surface course should be extended at least 2 feet from the edge of the trench. This design minimizes the reflective cracking due to excessive strains at the bottom of each layer at the edge of the trench and allows better compaction of the base material and new HMAC. Diagrams for typical T-patches are shown below as Figure D.1 shows the details of trench repairs in both the crossing (transverse) direction and parallel (longitudinal) direction. Figures D.2 and D.3 are notes that comprise part of the specifications for the flush trench repairs and support the details in Figure D.1. Figures D.5 and D.6 are notes that comprise part of the specifications for the recessed trench repairs and support the details in Figure D.4. Figure D.7 provides details for trench repairs outside the roadway. Figure D.8 provides details for temporary patch.

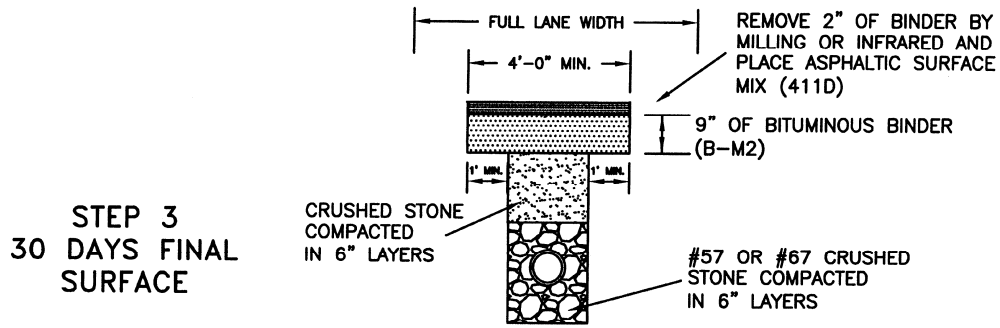
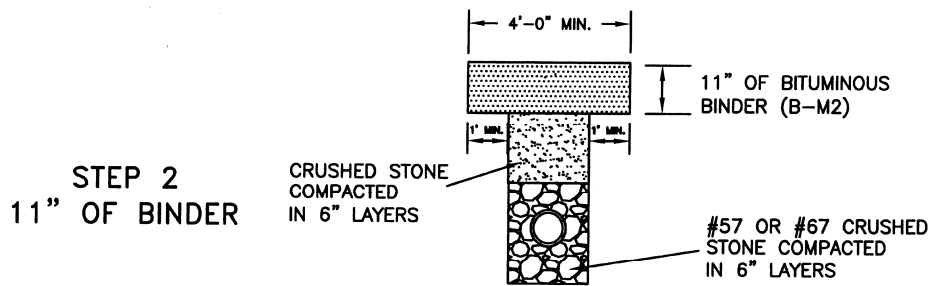
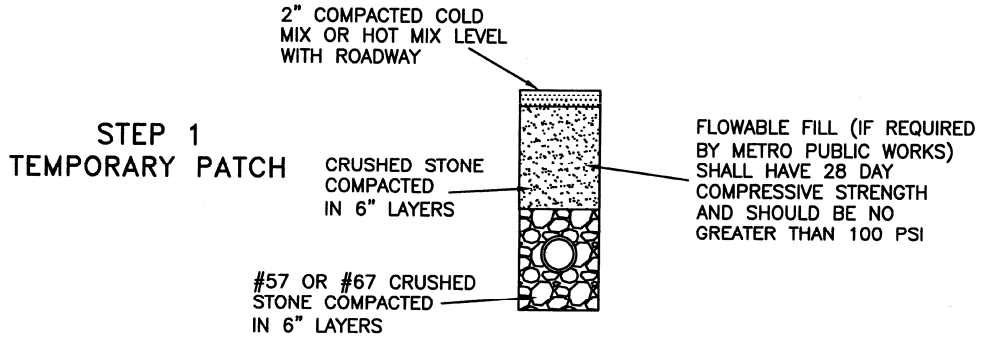

NOT TO SCALE

<p>METROPOLITAN GOVERNMENT OF NASHVILLE AND DAVIDSON COUNTY DEPARTMENT OF PUBLIC WORKS</p>	<p>FLUSH TRENCH REPAIR</p>	<p>DWG. NO. ST-270</p>
<p>DIR. OF ENG.: <i>Mark My</i></p>	<p>DATE: 1/13/09</p>	<p>REVISED: 01/06/06 REVISED: 04/01/08 REVISED: 11/17/08</p>

Figure D.1 Details of a flush trench repair.

1. PRIOR TO PLACEMENT OF CRUSHED STONE OR FLOWABLE FILL THE DEPARTMENT OF PUBLIC WORKS PERMITS OFFICE WILL BE NOTIFIED AND AN INSPECTION OF THE TRENCH WILL BE MADE BY A REPRESENTATIVE OF THE DEPARTMENT OF PUBLIC WORKS PERMITS OFFICE. AT THE COMPLETION OF THE INSTALLATION OF THE CRUSHED STONE OR FLOWABLE FILL, THE DEPARTMENT OF PUBLIC WORKS PERMITS OFFICE WILL BE NOTIFIED AND AN INSPECTION OF THE BACKFILL WILL BE MADE BY A REPRESENTATIVE OF THE DEPARTMENT OF PUBLIC WORKS. AFTER ACCEPTANCE OF THE BACKFILL BY THE REPRESENTATIVE OF THE DEPARTMENT OF PUBLIC WORKS PERMITS OFFICE, THE ASPHALT PAVEMENT CAN BE APPLIED.
2. INSPECTION PERSONNEL OF THE DEPARTMENT OF PUBLIC WORKS SHALL BE NOTIFIED BY CONTRACTOR/PERMITEE AT LEAST TWO (2) DAYS PRIOR TO REQUEST FOR INSPECTION.
3. THE WORK PERFORMED SHALL BE FREE FROM WORKMANSHIP DEFECTS FOR A PERIOD OF ONE (1) YEAR AFTER THE DATE OF ACCEPTANCE BY THE DEPARTMENT OF PUBLIC WORKS PERMIT OFFICE.
4. EXISTING PAVEMENTS, BASES, CURBS & GUTTERS AND SIDEWALKS SHALL BE CUT AND BROUGHT TO A NEAT LINE BY USE OF AN AIR HAMMER, SAW OR OTHER SUITABLE EQUIPMENT. EXPANSION JOINTS REMOVED SHALL BE REPLACED
5. THE MINIMUM WIDTH TO BE TRIMMED ON EACH SIDE OF THE TRENCH LINE, AS SEEN IN THE SECTION MAY BE WAIVED OR AMENDED UPON APPROVAL OF THE METRO INSPECTOR, HOWEVER, A MINIMUM WIDTH OF REPLACEMENT SHALL BE 4'-0" TO ALLOW FOR A ROLLER.
6. IF PERMANENT PAVEMENT REPAIRS CANNOT BE MADE WITHIN THREE (3) DAYS, THEN TEMPORARY REPLACEMENT SHALL BE MADE WITH 2" COLD MIX OR HOT BITUMINOUS SEAL COAT OVER COMPACTED CRUSHED STONE. PERMANENT PAVEMENT REPAIR TO BE COMPLETED WITHIN THE TIME PERIOD AS PER METRO CODE 13.20.
7. ALL EXCAVATIONS MADE WITHIN PUBLIC RIGHT-OF-WAY REQUIRE EXCAVATIONS AND STREET CLOSURE PERMITS FROM THE DEPARTMENT OF PUBLIC WORKS PRIOR TO COMMENCING WORK AS PER METRO CODE 13.20.
8. FLOWABLE FILL WILL BE REQUIRED ON ALL ARTERIALS, COLLECTORS AND DOWNTOWN STREETS. FLOWABLE FILL SHALL MEET THE REQUIREMENTS IN TENNESSEE DEPARTMENT OF TRANSPORTATION STANDARD SPECIFICATIONS SECTION 204, EXCEPT AS MODIFIED BY PUBLIC WORKS TECHNICAL SPECIFICATIONS 02225, LATEST REVISION.
9. IN THE EVENT OF ANY CONFLICT, DISCREPANCY, OR INCONSISTENCY AMONG THE PLANS AND THESE STANDARD DETAILS, THE REQUIREMENTS OF THE STANDARD DETAILS SHALL GOVERN.
10. ALL REPAIRS SHALL INCLUDE FULL LANE WIDTH RESURFACING EXCEPT WHEN UTILIZING INFRARED TECHNOLOGY. SEE INFRARED SPECIFICATIONS ATTACHED. THERE WILL BE A MAXIMUM OF 40 FT LONGITUDINAL REPAIR WHEN USING INFRARED TECHNOLOGY ON AN EXCAVATED PATCH.
11. ALL REPAIRS SHALL UTILIZE A 1-FOOT CUTBACK ON ALL SIDES EXCEPT THE EDGE OF PAVEMENT.

NOT TO SCALE

METROPOLITAN GOVERNMENT OF NASHVILLE AND DAVIDSON COUNTY DEPARTMENT OF PUBLIC WORKS	FLUSH TRENCH REPAIR NOTES	DWG. NO. ST-270a
DIR. OF ENG.: <i>Mark May</i>	DATE: <i>12/8/08</i>	REVISED: 07/31/02 REVISED: 09/10/04 REVISED: 11/17/08

Figure D.2. Page 1 of notes pertaining to a flush trench repair.

GENERAL NOTES CONTINUED:

12. NEW UTILITY CUTS WILL BE MILLED AND PAVED TO ANY EXISTING UTILITY CUT OR DAMAGED PAVEMENT WITHIN 10- FEET. IF EXISTING CUT OR DAMAGED PAVEMENT IS LESS THAN 10- FEET IN LENGTH, THE EXISTING CUT OR DAMAGED PAVEMENT SHALL ALSO BE MILLED AND PAVED.
13. ASPHALT REPAIR ADJACENT TO CURB AND GUTTER ALONG A ROADWAY GREATER THAN 24- INCHES SHALL HAVE FULL LANE WIDTH PAVING.
14. WHEN GRADED STONE (I.E. #57, #67, #78 STONE) IS USED THERE IS GENERALLY NO COMPACTION EQUIPMENT REQUIRED. THE MATERIAL DOES, HOWEVER, NEED TO BE PUT IN THE TRENCH IN APPROXIMATELY 12- INCH LIFTS.
15. GRADED STONE PLACED IN TRENCH SHOULD BE CAPPED WITH 8 TO 12- INCHES OF PUG MIX (MIX IS ESSENTIALLY TYPE A BASE, GRADE D, OR MORE COMMONLY KNOWN AS "CRUSHER RUN"). SEE TDOT STANDARD SPECIFICATION 303.07.
16. TYPE "A" BASE, GRADE "D" CAN BE USED FOR THE ENTIRE BACKFILL AND COMPACTED BY MECHANICAL METHODS IN NO MORE THAN 6- INCH LIFTS AS PROVIDED IN SECTION 204.11 OF TDOT STANDARD SPECIFICATIONS.
17. THE PUG MIX SHOULD BE COMPACTED IN 6- INCH LIFTS WITH A STEEL SHELL ROLLER OR OTHER MECHANICAL VIBRATORY COMPACTION EQUIPMENT. SEE TDOT STANDARD SPECIFICATIONS 303.08 AND 303.09. MATERIAL SHOULD BE ALLOWED TO CURE UNTIL ALL THE MOISTURE IS GONE FROM STONE (USUALLY 24-48 HOURS).
18. THE TRENCH SHOULD THEN HAVE 11- INCHES OF BINDER PLACED LEVEL WITH THE ROADWAY IN A MINIMUM OF TWO (2) LIFTS AND COMPACTED WITH MECHANICAL COMPACTION EQUIPMENT.
19. THE BINDER SURFACE SHALL BE MILLED OR HEATED USING INFRARED TECHNOLOGY TWO 2- INCHES IN DEPTH AND REPLACED WITH TWO (2) INCHES OF SURFACE MIX AND COMPACTED WITH MECHANICAL COMPACTION EQUIPMENT.
20. INTERSECTION REPAIRS WILL ONLY REQUIRE FULL LANE WIDTH PAVING.
22. ANY DISTURBED PAVEMENT MARKINGS MUST BE RESTORED TO CURRENT METRO STANDARDS.
23. DIAGONAL REPAIRS WILL BE REQUIRED TO BE SQUARED OFF AND MILLED AND PAVED. NO INFRARED TECHNOLOGY ALLOWED ON THIS TYPE OF REPAIR.
24. ALL LONGITUDINAL REPAIRS MORE THAN 40 FT IN LENGTH WILL BE REQUIRED TO BE MILLED AND PAVED.

NOT TO SCALE

<p>METROPOLITAN GOVERNMENT OF NASHVILLE AND DAVIDSON COUNTY DEPARTMENT OF PUBLIC WORKS</p>	<p>FLUSH TRENCH REPAIR NOTES</p>	<p>DWG. NO. ST-270b</p>
<p>DIR. OF ENG.: <i>Mark Macy</i></p>	<p>DATE: <i>12/2/08</i></p>	<p>REVISED: 03/31/06 REVISED: 11/17/08 REVISED:</p>

Figure D.3. Page 2 of notes pertaining to a flush trench repair.

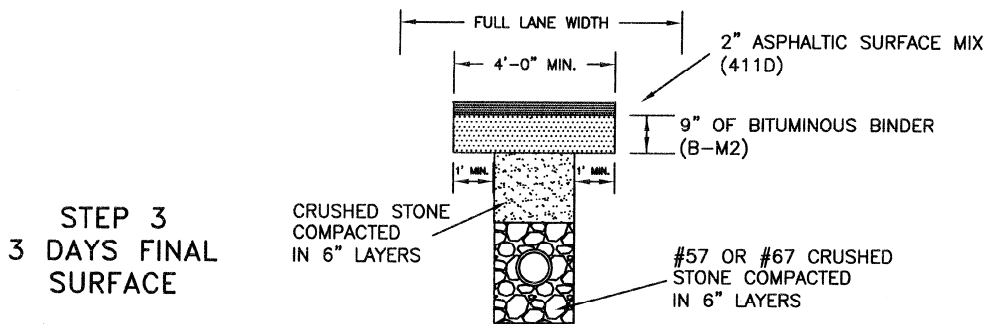
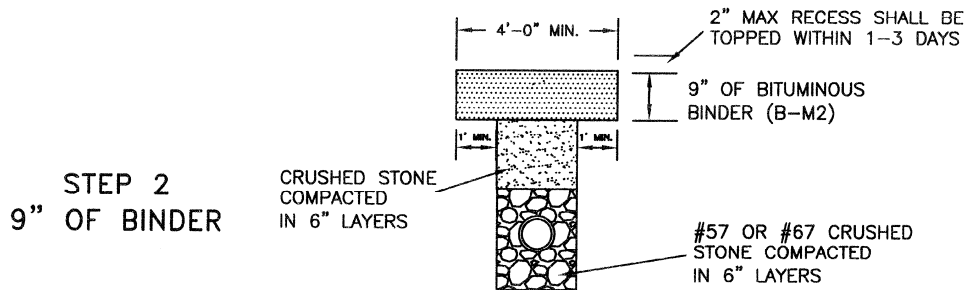
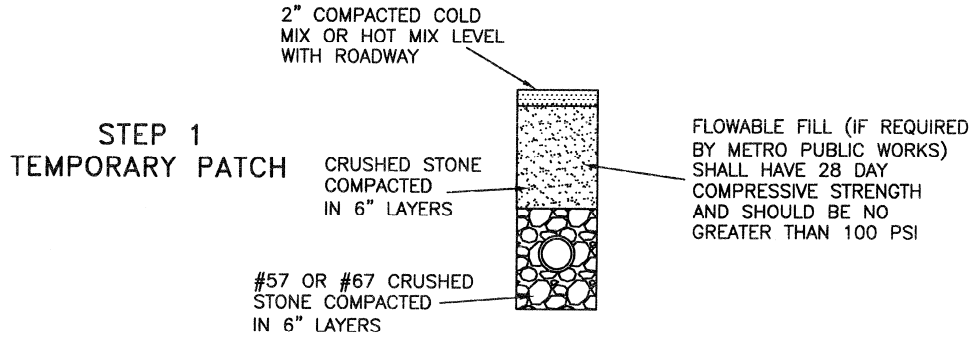

NOT TO SCALE

<p>METROPOLITAN GOVERNMENT OF NASHVILLE AND DAVIDSON COUNTY DEPARTMENT OF PUBLIC WORKS</p>	<p>RECESSED TRENCH REPAIR</p>	<p>DWG. NO. ST-271</p>
<p>DIR. OF ENG.: <i>Mark Murcy</i></p>	<p>DATE: <i>12/2/08</i></p>	<p>REVISED: 01/06/06 REVISED: 04/01/08 REVISED: 11/17/08</p>

Figure D.4. Details of a recessed trench repair.

1. PRIOR TO PLACEMENT OF CRUSHED STONE OR FLOWABLE FILL THE DEPARTMENT OF PUBLIC WORKS PERMITS OFFICE WILL BE NOTIFIED AND AN INSPECTION OF THE TRENCH WILL BE MADE BY A REPRESENTATIVE OF THE DEPARTMENT OF PUBLIC WORKS PERMITS OFFICE. AT THE COMPLETION OF THE INSTALLATION OF THE CRUSHED STONE OR FLOWABLE FILL, THE DEPARTMENT OF PUBLIC WORKS PERMITS OFFICE WILL BE NOTIFIED AND AN INSPECTION OF THE BACKFILL WILL BE MADE BY A REPRESENTATIVE OF THE DEPARTMENT OF PUBLIC WORKS. AFTER ACCEPTANCE OF THE BACKFILL BY THE REPRESENTATIVE OF THE DEPARTMENT OF PUBLIC WORKS PERMITS OFFICE, THE ASPHALT PAVEMENT CAN BE APPLIED.
2. INSPECTION PERSONNEL OF THE DEPARTMENT OF PUBLIC WORKS SHALL BE NOTIFIED BY CONTRACTOR/PERMITEE AT LEAST TWO (2) DAYS PRIOR TO REQUEST FOR INSPECTION.
3. THE WORK PERFORMED SHALL BE FREE FROM WORKMANSHIP DEFECTS FOR A PERIOD OF ONE (1) YEAR AFTER THE DATE OF ACCEPTANCE BY THE DEPARTMENT OF PUBLIC WORKS PERMIT OFFICE.
4. EXISTING PAVEMENTS, BASES, CURBS & GUTTERS AND SIDEWALKS SHALL BE CUT AND BROUGHT TO A NEAT LINE BY USE OF AN AIR HAMMER, SAW OR OTHER SUITABLE EQUIPMENT. EXPANSION JOINTS REMOVED SHALL BE REPLACED.
5. THE MINIMUM WIDTH TO BE TRIMMED ON EACH SIDE OF THE TRENCH LINE, AS SEEN IN THE SECTION MAY BE WAIVED OR AMENDED UPON APPROVAL OF THE METRO INSPECTOR, HOWEVER, A MINIMUM WIDTH OF REPLACEMENT SHALL BE 4'-0" TO ALLOW FOR A ROLLER.
6. IF PERMANENT PAVEMENT REPAIRS CANNOT BE MADE WITHIN THREE (3) DAYS, THEN TEMPORARY REPLACEMENT SHALL BE MADE WITH 2" COLD MIX OR HOT BITUMINOUS SEAL COAT OVER COMPACTED CRUSHED STONE. PERMANENT PAVEMENT REPAIR TO BE COMPLETED WITHIN THE TIME PERIOD AS PER METRO CODE 13.20.
7. ALL EXCAVATIONS MADE WITHIN PUBLIC RIGHT-OF-WAY REQUIRE EXCAVATIONS AND STREET CLOSURE PERMITS FROM THE DEPARTMENT OF PUBLIC WORKS PRIOR TO COMMENCING WORK AS PER METRO CODE 13.20.
8. FLOWABLE FILL WILL BE REQUIRED ON ALL ARTERIALS, COLLECTORS AND DOWNTOWN STREETS. FLOWABLE FILL SHALL MEET THE REQUIREMENTS IN TENNESSEE DEPARTMENT OF TRANSPORTATION STANDARD SPECIFICATIONS SECTION 204, EXCEPT AS MODIFIED BY PUBLIC WORKS TECHNICAL SPECIFICATIONS 02225, LATEST REVISION.
9. IN THE EVENT OF ANY CONFLICT, DISCREPANCY, OR INCONSISTENCY AMONG THE PLANS AND THESE STANDARD DETAILS, THE REQUIREMENTS OF THE STANDARD DETAILS SHALL GOVERN.
10. ALL REPAIRS SHALL INCLUDE FULL LANE WIDTH RESURFACING EXCEPT WHEN UTILIZING INFRARED TECHNOLOGY. SEE INFRARED SPECIFICATIONS ATTACHED. THERE WILL BE A MAXIMUM OF 40 FT LONGITUDINAL REPAIR WHEN USING INFRARED TECHNOLOGY ON AN EXCAVATED PATCH.
11. ALL REPAIRS SHALL UTILIZE A 1-FOOT CUTBACK ON ALL SIDES EXCEPT THE EDGE OF PAVEMENT.

NOT TO SCALE

METROPOLITAN GOVERNMENT OF NASHVILLE AND DAVIDSON COUNTY DEPARTMENT OF PUBLIC WORKS	RECESSED TRENCH REPAIR NOTES	DWG. NO. ST-271a
DIR. OF ENG.: <i>Mark Macy</i>	DATE: <i>12/8/08</i>	REVISED: 07/31/02 REVISED: 09/10/04 REVISED: 11/17/08

Figure D.5. Page 1 of notes pertaining to a recessed trench repair.

GENERAL NOTES CONTINUED:

12. NEW UTILITY CUTS WILL BE MILLED AND PAVED TO ANY EXISTING UTILITY CUT OR DAMAGED PAVEMENT WITHIN 10- FEET. IF EXISTING CUT OR DAMAGED PAVEMENT IS LESS THAN 10- FEET IN LENGTH, THE EXISTING CUT OR DAMAGED PAVEMENT SHALL ALSO BE MILLED AND PAVED.
13. ASPHALT REPAIR ADJACENT TO CURB AND GUTTER ALONG A ROADWAY GREATER THAN 24- INCHES SHALL HAVE FULL LANE WIDTH PAVING.
14. WHEN GRADED STONE (I.E. #57, #67, #78 STONE) IS USED THERE IS GENERALLY NO COMPACTION EQUIPMENT REQUIRED. THE MATERIAL DOES, HOWEVER, NEED TO BE PUT IN THE TRENCH IN APPROXIMATELY 12- INCH LIFTS.
15. GRADED STONE PLACED IN TRENCH SHOULD BE CAPPED WITH 8 TO 12- INCHES OF PUG MIX (MIX IS ESSENTIALLY TYPE A BASE, GRADE D, OR MORE COMMONLY KNOWN AS "CRUSHER RUN"). SEE TDOT STANDARD SPECIFICATION 303.07.
16. TYPE "A" BASE, GRADE "D" CAN BE USED FOR THE ENTIRE BACKFILL AND COMPACTED BY MECHANICAL METHODS IN NO MORE THAN 6- INCH LIFTS AS PROVIDED IN SECTION 204.11 OF TDOT STANDARD SPECIFICATIONS.
17. THE PUG MIX SHOULD BE COMPACTED IN 6- INCH LIFTS WITH A STEEL SHELL ROLLER OR OTHER MECHANICAL VIBRATORY COMPACTION EQUIPMENT. SEE TDOT STANDARD SPECIFICATIONS 303.08 AND 303.09. MATERIAL SHOULD BE ALLOWED TO CURE UNTIL ALL THE MOISTURE IS GONE FROM STONE (USUALLY 24-48 HOURS).
18. THE TRENCH SHOULD THEN HAVE 11- INCHES OF BINDER PLACED LEVEL WITH THE ROADWAY IN A MINIMUM OF TWO (2) LIFTS AND COMPACTED WITH MECHANICAL COMPACTION EQUIPMENT.
19. ASPHALT SURFACE MATERIAL SHOULD BE PLACED AT 2- INCH THICKNESS AND COMPACTED WITHIN 1-3 DAYS AFTER THE BINDER IS PLACED.
20. INTERSECTION REPAIRS WILL ONLY REQUIRE FULL LANE WIDTH PAVING.

NOT TO SCALE

METROPOLITAN GOVERNMENT OF NASHVILLE AND DAVIDSON COUNTY DEPARTMENT OF PUBLIC WORKS	RECESSED TRENCH REPAIR NOTES	DWG. NO. ST-271b
DIR. OF ENG.: <i>Mark Mary</i>	DATE: <i>12/2/08</i>	REVISED: 03/31/06 REVISED: 11/17/08 REVISED:

Figure D.6. Page 2 of notes pertaining to a recessed trench repair

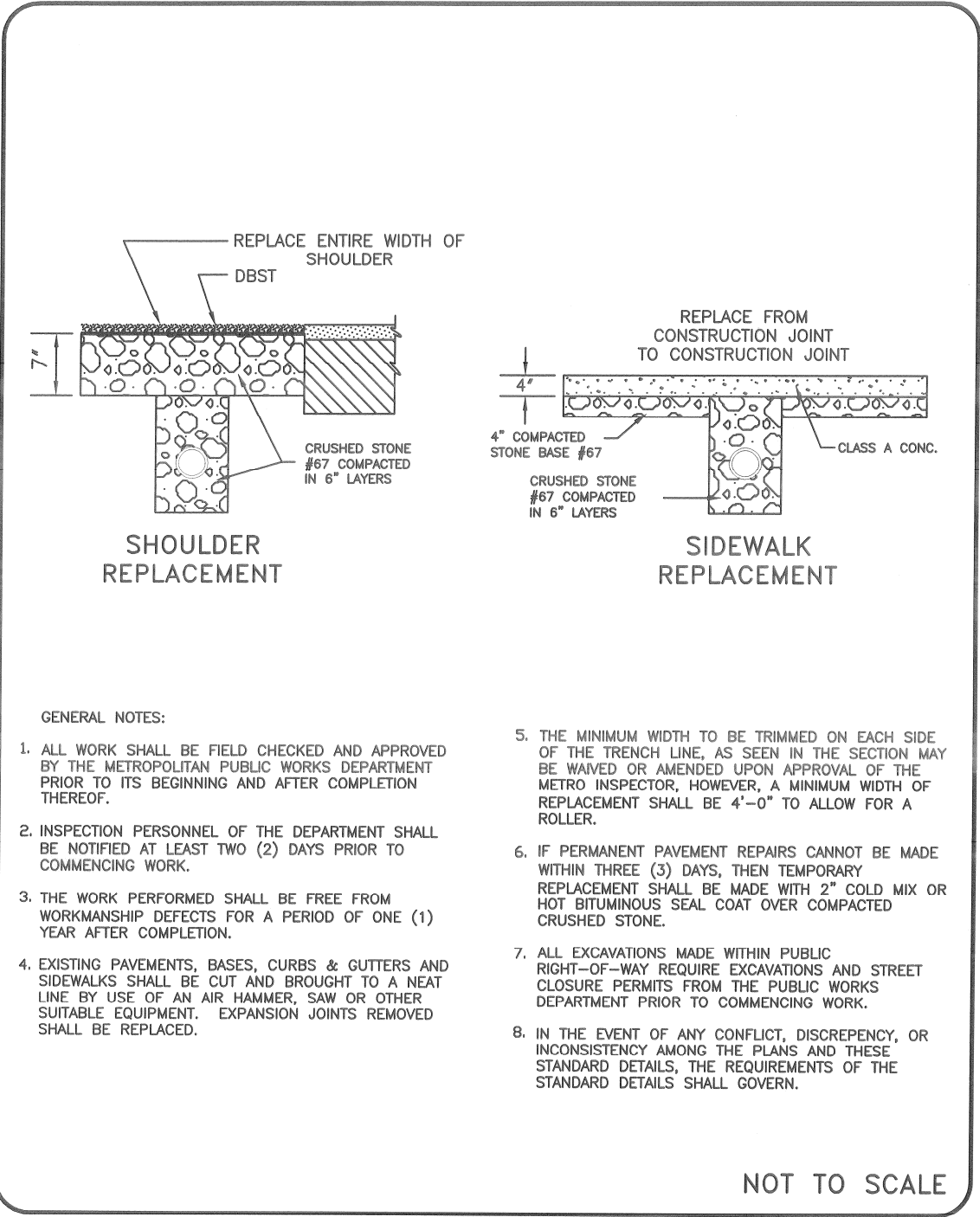

METROPOLITAN GOVERNMENT OF NASHVILLE AND DAVIDSON COUNTY DEPARTMENT OF PUBLIC WORKS	TRENCH REPAIR OUTSIDE ROADWAY	DWG. NO. ST-272
DIR. OF ENG.: <i>Mark Macy</i> DATE: <i>9/10/04</i>		REVISED: 12/01/00 REVISED: 06/23/04 REVISED: 09/10/04

Figure D.7. Details for trench repair outside of roadway.

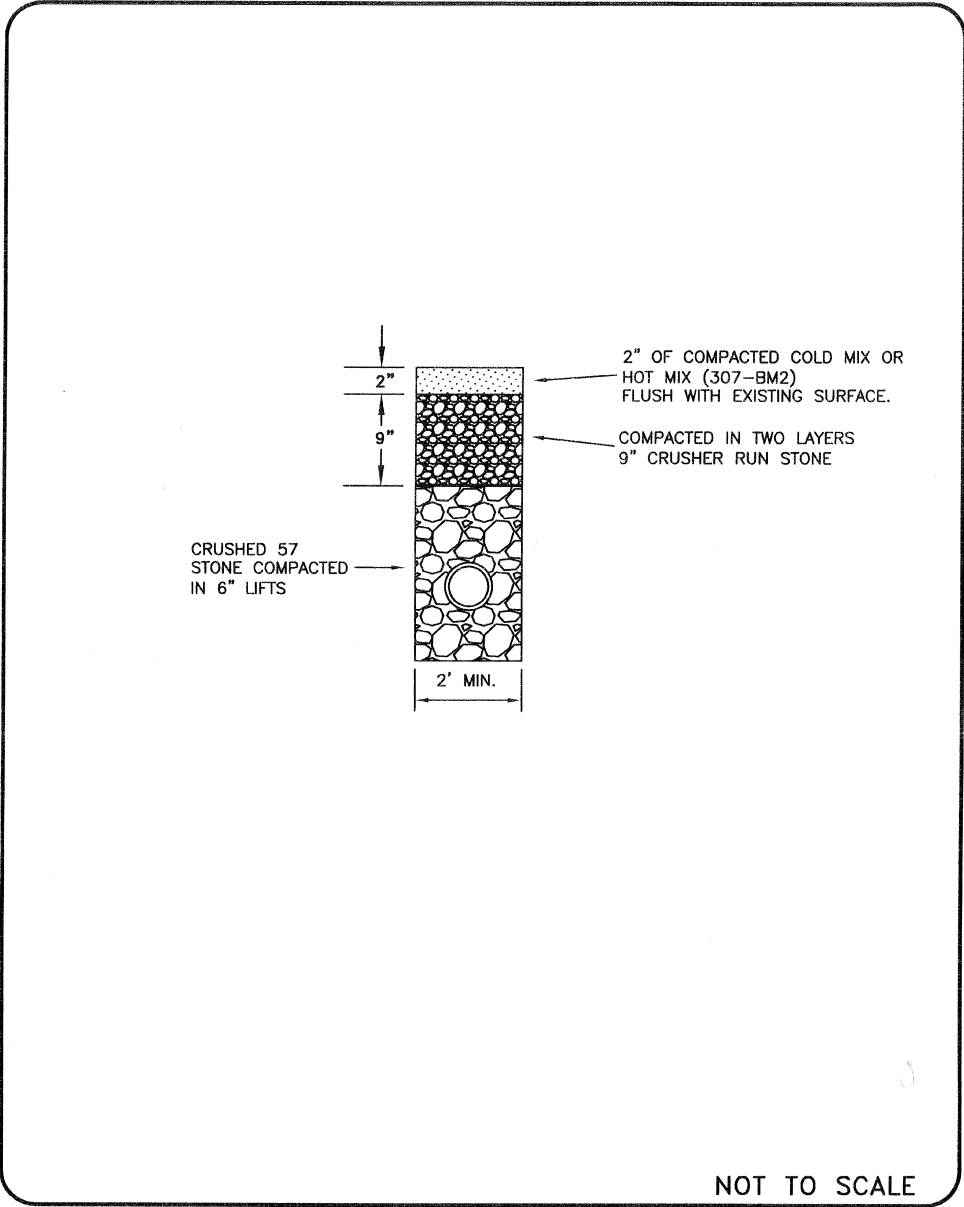

METROPOLITAN GOVERNMENT OF NASHVILLE AND DAVIDSON COUNTY DEPARTMENT OF PUBLIC WORKS	TEMPORARY PATCH SPECIFICATIONS	DWG. NO. ST-276
DIR. OF ENG.: <i>Mark May</i>	DATE: <i>6/16/08</i>	REVISED: 06/10/08 REVISED: REVISED:

- Figure D.8. Details for a temporary patch

D.4 UTILITY CUT GUIDELINES

Guidelines for consideration when updating the existing specification are presented in this section. The recommended practices can be easily converted to specifications and incorporated into the appropriate sections of Chapter 13.20 of the Metro Code.

D.4.1 General Requirements

All contractors and public utility agencies must obtain a ROW Permit for any work performed within the public rights-of-way of Metropolitan Nashville and Davidson County. The storage of materials and equipment within the public rights-of-way also requires a permit.

To preserve the original investment of the street and roadway systems, minimize the disruption and maximize the safety to the traveling public caused by construction, and reduce future maintenance problems, it is the policy of some agencies to require the installation of new utilities across existing streets be done by boring or tunneling. Open cutting of existing streets for the installation of new utilities will be permitted only when it can be proven it is not possible to use boring or tunneling techniques.

Applicants for Right-of-Way Permits must plan for adequate time for review and approval by the MPW and any other involved agencies. Generally, the greater the scope of work, the longer the permit review and approval process will take. Definitions and Abbreviations are found in the Glossary in Appendix C.

Upon obtaining a permit and after making the cut, the applicants are required to repair the streets using a quality approach to preserve the value of the street.

D.4.2 Quality Requirements

Every street and street repair situation is unique. Design criteria and construction standards cannot address every situation but, in order to maintain some form of consistency, these standards have been developed. In most cases, they provide the minimum acceptable standards for construction or repair. Consequently, when strictly applied, they will provide the minimally acceptable product. Therefore, this criteria has been developed to maintain the same integrity of the street pavement and subsurface condition prior to its being cut for utility installations.

The proposed criteria are guidelines to achieve the goal of "Quality" in street repairs. When used in conjunction with good planning and judgment, the repair methods will maintain the street at an acceptable condition with minimal patching failures.

Quality assurance measures, recommended further in this chapter, should be enforced to ensure the desired quality level.

D.4.3 Appearance of Utility Cut Repairs

The final appearance of the street after the repairs are made should be acceptable with an engineered appearance. Street repairs that are satisfactory from a functional point of view may produce a negative reaction from the public if they give the appearance of being poorly planned or executed. The public's perception of street repairs is based primarily on shape, size, and orientation--the geometry of a patch. Following are guidelines for the geometry of a quality patch:

- Street repairs should leave a pavement in a condition at least as good as, if not better than, the condition prior to the repairs. In most cases, and particularly in the cases of extensive excavation and repairs, it is desirable to survey the existing pavement condition with a representative of MPW prior to the work. After completion of the work, survey the pavement condition again to verify that the pavement condition has been maintained or improved. In the case of minor repairs, these pavement surveys can be made by visual observation.
- In the case of major projects that involve excessive haul of materials or unusually heavy construction equipment or activity, non-destructive testing of the pavement condition before and after construction may be required.
- Excavations and street repairs, even well constructed street repairs, shorten a pavement's life. Several types of street distress, settlement, alligator cracking, and potholes, often show up around patches. Quality street repairs should attempt to reduce the occurrence of these types of distress.
- Avoid weakening or destroying the existing pavement around an excavation with heavy construction equipment, stockpiling, or delivery of materials, etc. When damage does occur, remove the damaged pavement, extending the limits of the street repair, before replacing the pavement. No stockpiling of backfill or road building materials is permitted on the pavement.

D.4.4 Utility Cut Repair Details

Figures D.9 through D.11 show the acceptable methods for making utility cut repairs in intersections. Figure D.9 is the case where the utility cut is contained in only one quarter of the intersection; Figure D.10 is the case where the utility cut encompasses more than one quarter but is contained in one half of the intersection. Figure D.11 is for the case where the utility cut encompasses more than one half of the intersection.

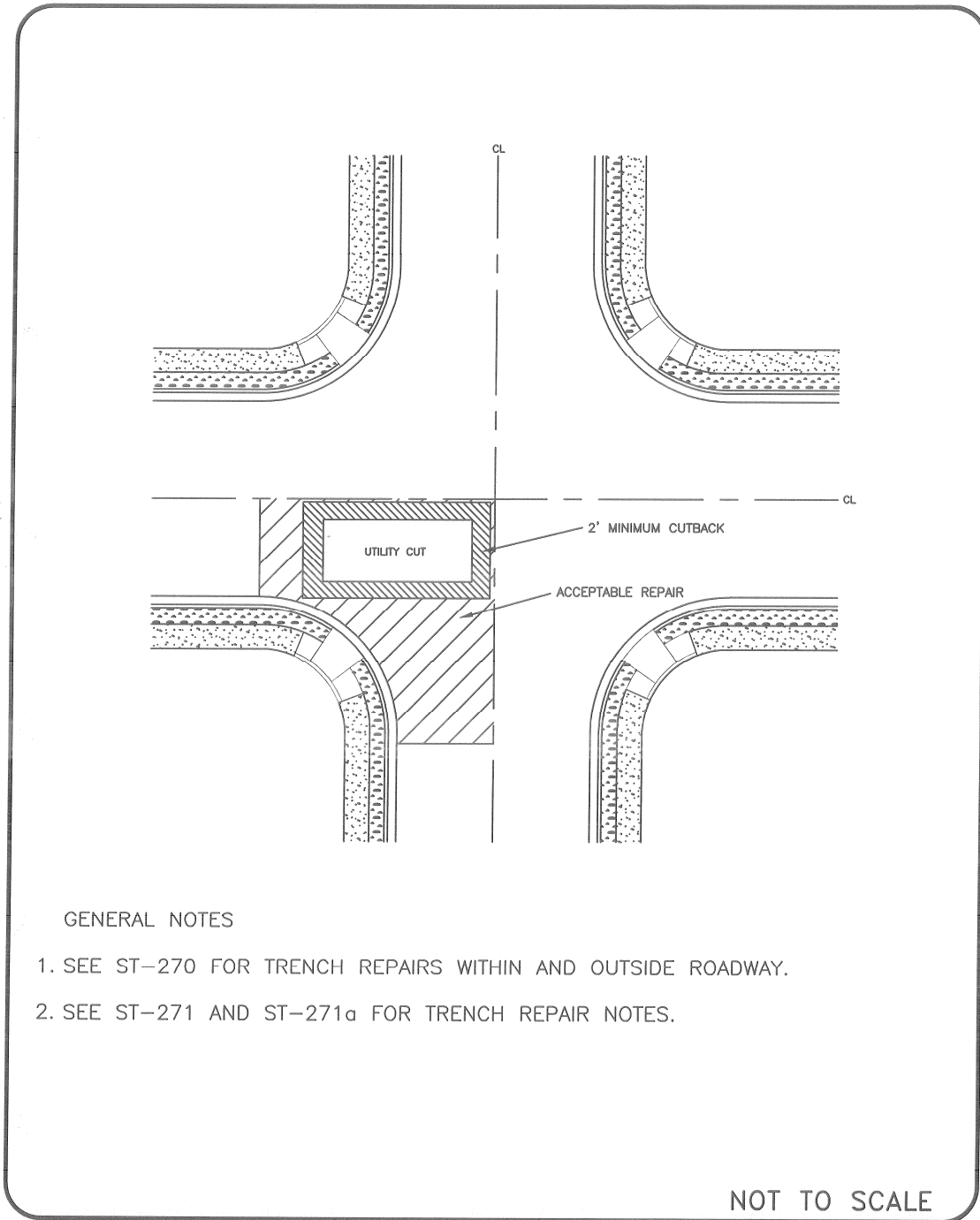

GENERAL NOTES

1. SEE ST-270 FOR TRENCH REPAIRS WITHIN AND OUTSIDE ROADWAY.
2. SEE ST-271 AND ST-271a FOR TRENCH REPAIR NOTES.

NOT TO SCALE

METROPOLITAN GOVERNMENT OF NASHVILLE AND DAVIDSON COUNTY DEPARTMENT OF PUBLIC WORKS	UTILITY CUT LOCATIONS AT INTERSECTIONS EXAMPLE 1	DWG. NO. ST-273
DIR. OF ENG.: <i>[Signature]</i>	DATE: 3/29/06	REVISED: 03/16/06 REVISED: REVISED:

Figure D.9. Utility cut contained in one quarter of intersection.

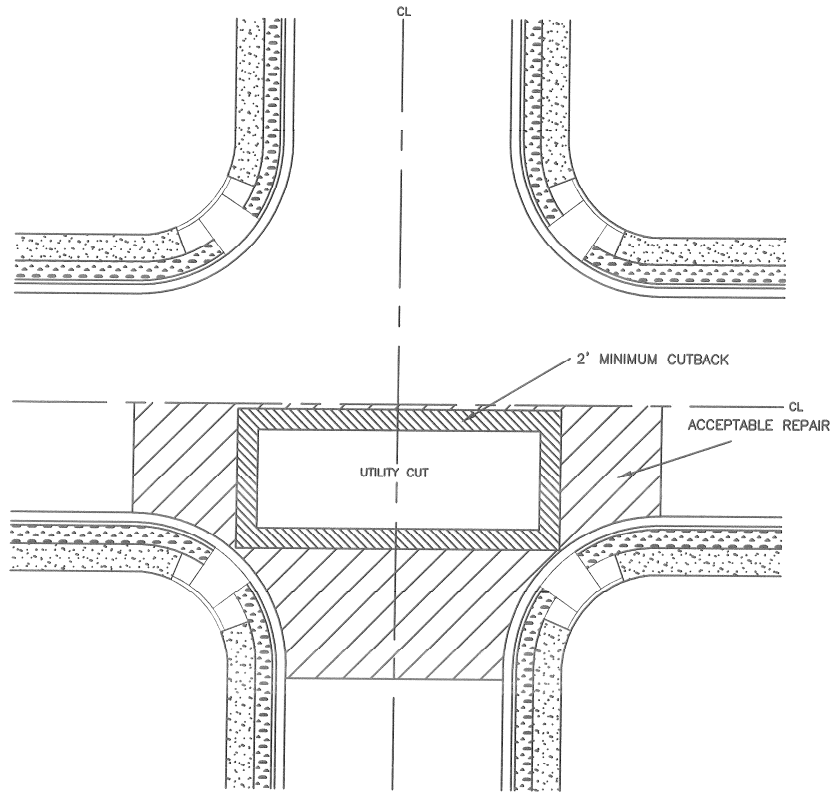

GENERAL NOTES

1. SEE ST-270 FOR TRENCH REPAIRS WITHIN AND OUTSIDE ROADWAY.
2. SEE ST-271 AND ST-271a FOR TRENCH REPAIR NOTES.

NOT TO SCALE

METROPOLITAN GOVERNMENT OF NASHVILLE AND DAVIDSON COUNTY DEPARTMENT OF PUBLIC WORKS	UTILITY CUT LOCATIONS AT INTERSECTIONS EXAMPLE 1	DWG. NO. ST-274
DIR. OF ENG.:	<i>Mark King</i> DATE: 3/29/06	REVISED: 03/16/06 REVISED: REVISED:

Figure D.10. Utility cut contained in one half of intersection.

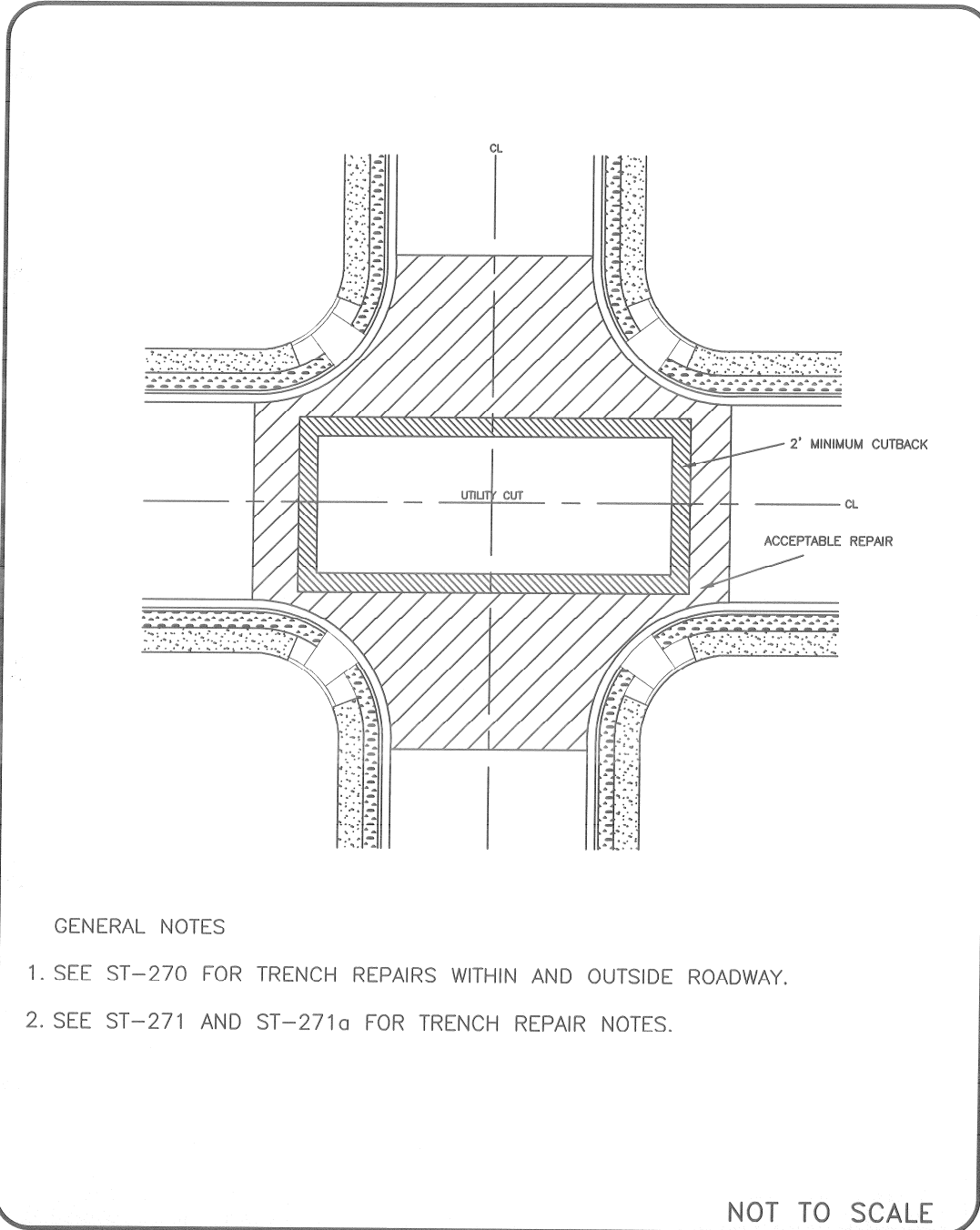

GENERAL NOTES

1. SEE ST-270 FOR TRENCH REPAIRS WITHIN AND OUTSIDE ROADWAY.
2. SEE ST-271 AND ST-271a FOR TRENCH REPAIR NOTES.

NOT TO SCALE

METROPOLITAN GOVERNMENT OF NASHVILLE AND DAVIDSON COUNTY DEPARTMENT OF PUBLIC WORKS	UTILITY CUT LOCATIONS AT INTERSECTIONS EXAMPLE 3	DWG. NO. ST-275
DIR. OF ENG.: <i>Mark May</i>	DATE: <i>3/29/06</i>	REVISED: 03/16/06 REVISED: REVISED:

Figure D.11. Utility cut contained encompasses more than one-half of intersection.

Some examples of repair methods that are not acceptable and the corresponding acceptable method are provided in the following Figures D.12 through D.24.

Example 1

Existing pavements should be removed to clean, straight lines parallel and perpendicular to the flow of traffic. Do not construct patches with angled sides and irregular shapes. All repairs should be full lane width.

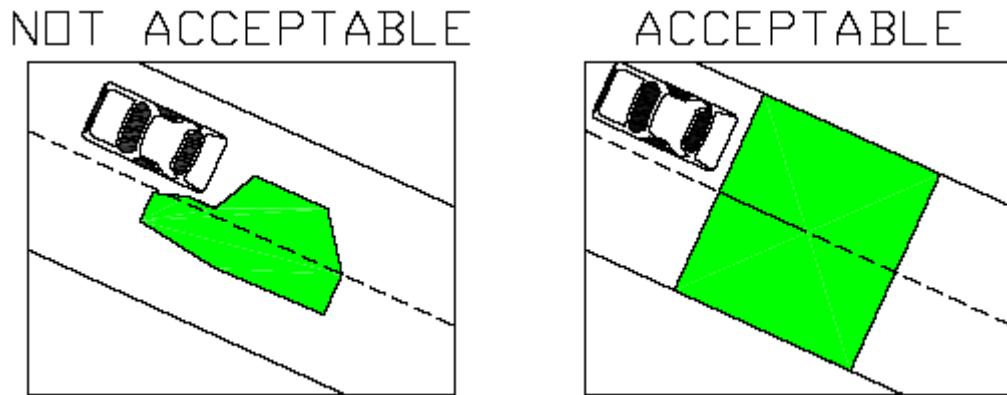

Figure D.12. Example 1: Do not construct patches with angled sides and irregular shapes.

Example 2

Avoid patches within existing patches. If this cannot be avoided, make the boundaries of the patches coincide. All repairs should be full lane width.

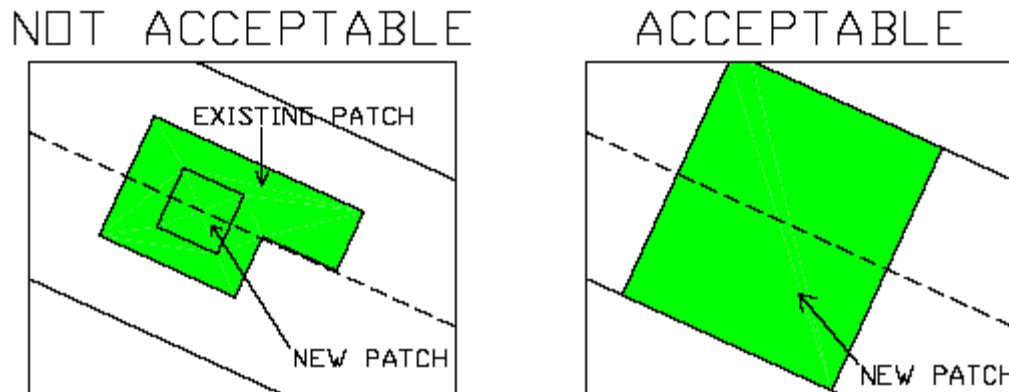

Figure D.13. Example 2: Avoid patches within existing patches.

Example 3

Do not leave strips of pavement less than one-half lane in width from the edge of the new patch to the edge of an existing patch or the lip of the gutter.

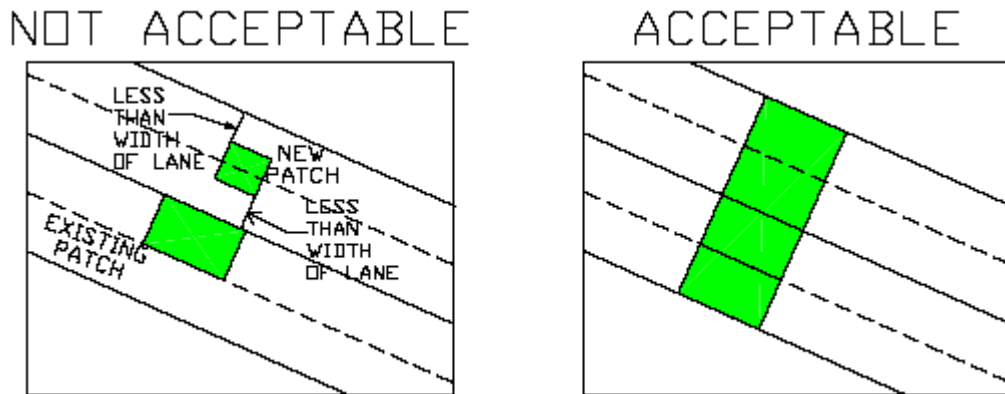

Figure D.14. Example 3: Do not leave strips of pavement less than one-half lane in width.

Example 4

In concrete pavements, remove sections to existing joints, or new saw cut joints at mid-slab, that are in good repair. In damaged concrete, the limits of removal should be determined in the field by a representative of MPW.

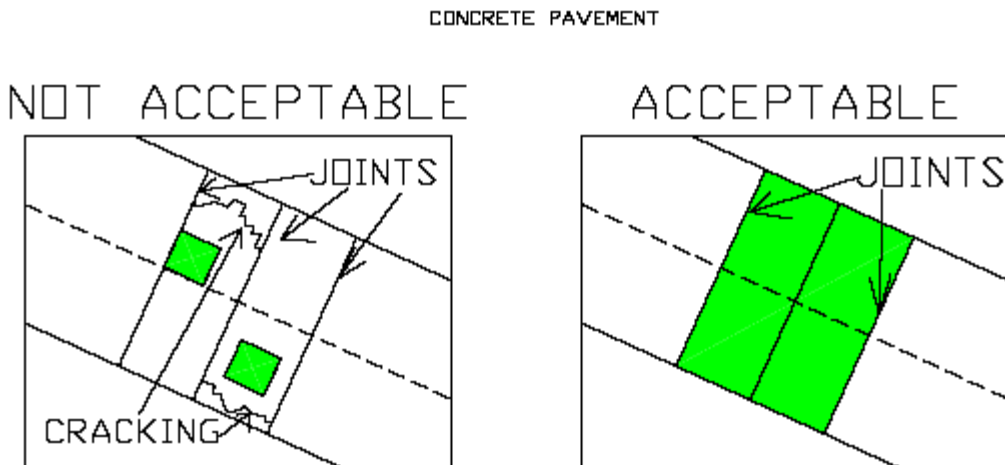

Figure D.15. Example 4: In concrete pavements, remove sections to existing joints.

Example 5

Asphalt and concrete pavements should be removed by saw cutting or grinding. Avoid breaking away the edges of the existing pavement or damaging the remaining pavement with heavy construction equipment.

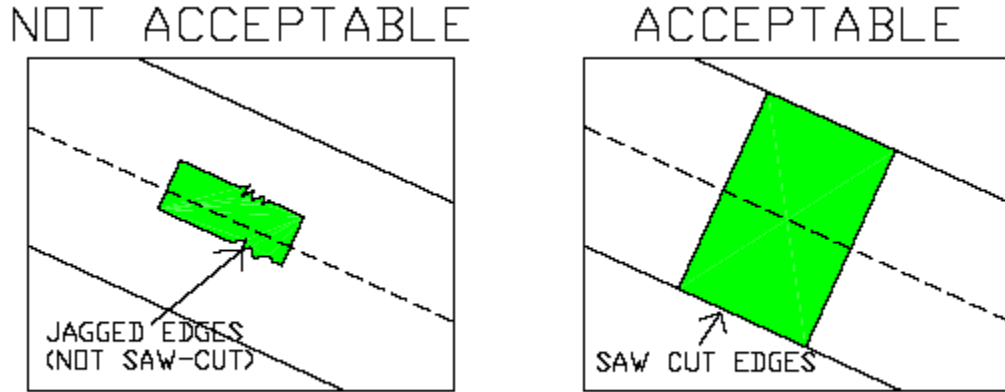

Figure D.16. Example 5: All edges shall be saw cut.

Example 6

In the case of a series of patches or patches for service lines off a main trench, repair the pavement over the patches by grinding and overlay when the spacing between the patches is less than 10 feet. In cases where the existing pavement is in poor condition (in the Strategic Paving Plan) and may require overlay within the next few years, this requirement may be modified or waived by the MPW Pavement Manager.

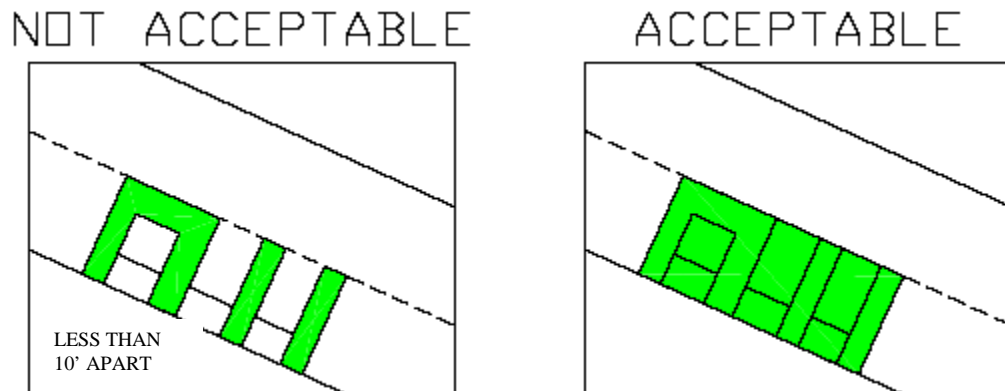

Figure D.17. Example 6: The patched area must include any existing patches within 10 feet.

Example 7

Completed street repairs should have rideability at least as good as, if not better than, the pavement prior to the repairs. A driver may be able to see a street repair, but in the case of a quality repair, should not be able to "feel" it in normal driving. A patch should provide a smooth ride with smooth transitions on and off the repair and all joints should be located outside the wheel path. Overlays should be placed by first removing the existing pavement to the desired depth by grinding or milling, and then placing the pavement flush with the adjacent surfaces. Overlays with feathered edges are not acceptable.

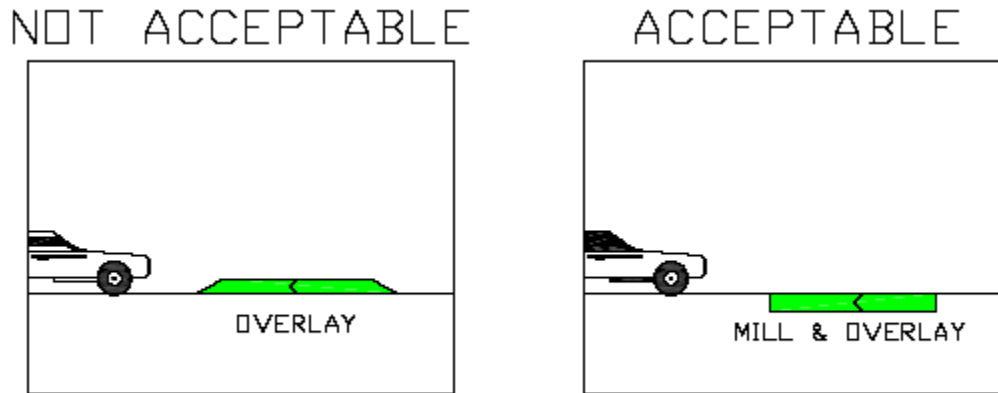

Figure D.18. Example 7: Patches may not decrease rideability.

Example 8

Surface tolerances for street repairs should meet the standard for new construction. That is, the finished surface of the street repair should be tested with a ten- (10-) foot straightedge parallel to the centerline or perpendicular across joints. Variations measured from the testing face of the straightedge to the surface of the street repair should not exceed one-quarter- ($1/4$ -) inch.

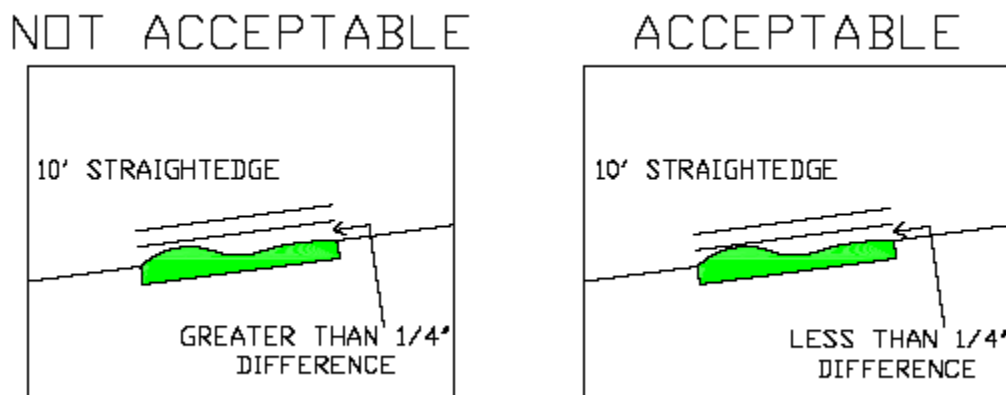
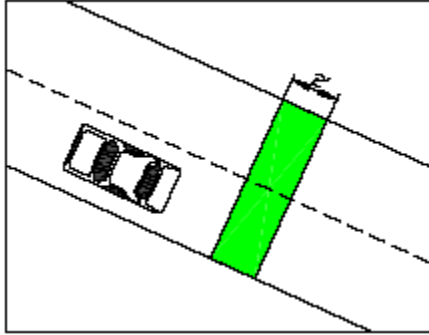

Figure D.19. Example 8: Surface tolerances for street repairs should meet the standard for new construction.

Example 9

Transverse patches on arterial and collector streets shall be overlaid across the entire street width for a distance of two- (2-) feet minimum on all sides of the trench using a T-Patch.

NOT ACCEPTABLE



ACCEPTABLE

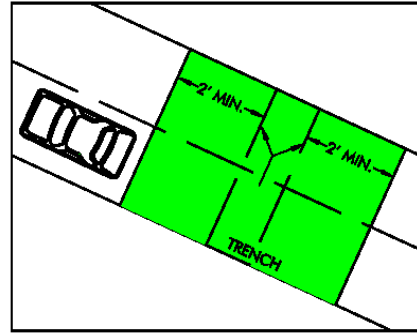
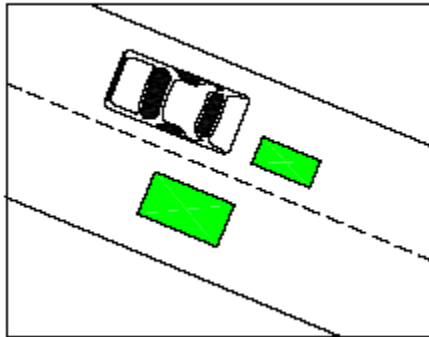

Figure D.20. Example 9: Trenches must be patched using a T-Patch.

Example 10

Do not allow the edges of patches to fall in existing wheel paths. The edges of patches parallel to the direction of traffic shall be limited to the boundaries of lanes or to the centerline of travel lanes.

NOT ACCEPTABLE



ACCEPTABLE

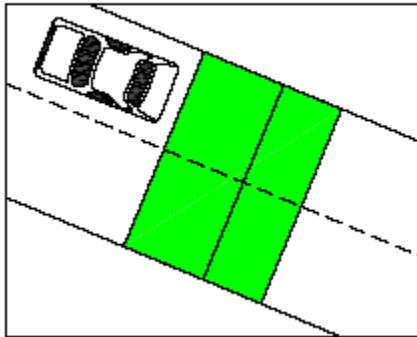

Figure D.21. Example 10: Do not allow the edges of patches to fall in wheel paths.

Example 11

Patches should have a smooth longitudinal grade consistent with the existing roadway. Patches should also have a cross slope or cross section consistent with the design of the existing roadway.

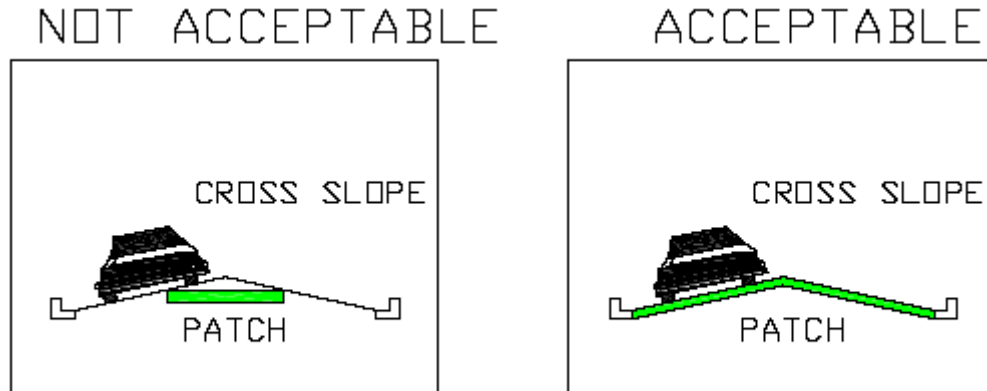

Figure D.22. Example 11. Patch slope and grade must match existing pavement.

Example 12

When the proposed excavation falls within 10 feet of a section of pavement damaged during the utility repair, the failed area shall be removed to sound pavement and patched. Scarring, gouging, or other damaged pavement adjacent to a patch shall be removed and the pavement repaired to the satisfaction of the MPW.

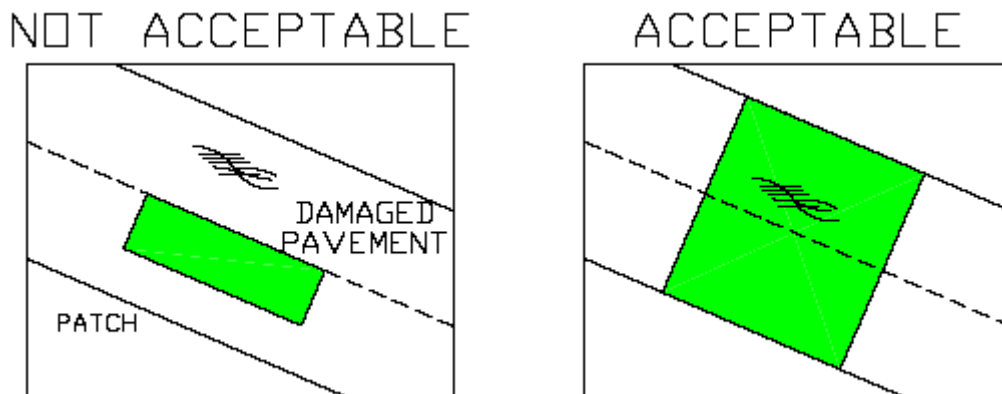

Figure D.23. Example 12: Damaged pavement within 10 feet of a patch must also be patched.

Example 13

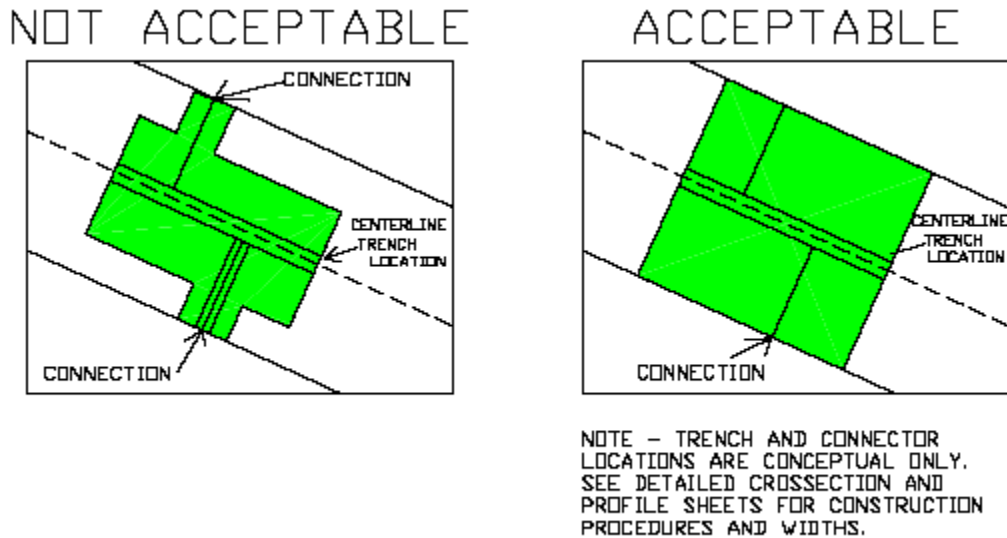

Figure D.24. Example 13: Patches must avoid frequent width changes.

D.5 TESTING AND INSPECTION

The contractor is required to provide material testing for each phase of the work and at no cost to MPW. The testing firm chosen to perform this work for the Contractor must be qualified and identified on the Permit application.

D.5.1 Testing Requirements

Density and thickness tests may be required to ensure compaction requirements are met and the appropriate compacted thickness of repair material has been placed. The number of tests required will be as directed by MPW. The costs of any testing, as required, shall be borne by the contractor. If sections with deficient thickness or density are found, the full section for a reasonable distance on each side of the deficiency shall be refused. All such sections shall be removed and reinstalled to these Guidelines.

D.5.2 Inspection Requirements

All construction work within the public rights-of-way shall be subject to inspection by MPW and certain types of work may have continuous inspection. It shall be the responsibility of the contractor to provide safe access for the inspector to perform the required inspections.

It shall be the responsibility of the person performing the work authorized by the Permit to notify MPW or an authorized representative that such work is ready for inspection. Every request for inspection is to be received at least twenty-four (24) hours before such inspection is desired. Such requests may be in writing or by telephoning or faxing MPW.

MPW may make or require other inspections of any work as deemed necessary to ascertain compliance with the provisions of these guidelines. Any work performed without the required inspections shall be subject to removal and replacement at the contractor's expense, regardless of the quality of the work.

Where large scale projects exceed the ability of the MPW to provide inspection, the contractor or utility company will incur the cost of a private inspection firm. This inspection firm will be mutually agreed upon by the Permit applicant and MPW prior to issuance of the Permit.

D.6 CONSTRUCTION DETAILS

The conditions described below apply to all work done within the public rights-of-way such as utility line installation or repairs performed by any contractor or utility department, public or private.

D.6.1 Protection of Existing Improvements

The contractor shall at all times take proper precautions and be responsible for the protection of existing street and alley surfaces, driveway culverts, street intersection culverts or aprons, irrigation systems, mail boxes, driveway approaches, curb, gutter and sidewalks and all other identifiable installations that may be encountered during construction.

The contractor shall, at all times, take proper precautions for the protection of existing utilities, the presence of which are known or can be determined by field locations of the utility companies. The contractor shall contact the local One Call for utility locations a minimum of two (2) working days prior to the proposed start of work.

Existing improvements to adjacent property such as landscaping, fencing, utility services, driveway surfaces, etc., which are not to be removed shall be protected from injury or damage resulting from the contractor's operations.

The contractor shall at all times take proper precautions for the protection of property pins/corners and survey control monuments encountered during construction. Any damaged or disturbed survey markers shall be replaced by a registered land surveyor at the contractor's expense.

The repair of any damaged improvements as described above shall be the responsibility of the permit holder.

The contractor shall make adequate provisions to assure that traffic and adjacent property owners experience a minimum of inconvenience

All work shall be done in an expedient manner. Repairs shall be made as rapidly as is consistent with high-quality workmanship and materials. Use of fast-setting concrete and similar techniques is encouraged whenever possible without sacrificing the quality of repair. For repairs 12 feet or less in length, completion of the work including replacement of pavement and cleanup shall normally be accomplished within two (2) weeks after the repair work or activity involving the cut is done. For repairs greater than 12 feet in length, the final surface shall not be placed for a minimum of 42 days from the placement of the binder material. Extension of time for completion, including winter and other weather delays, shall be with the written approval of MPW. If the repairs are not completed in the allotted time, MPW has the right to repair the street at the contractor's expense.

D.6.2 Temporary Surfaces Required

When the final surface is not immediately installed, it shall be necessary to place a temporary asphalt surface on any street cut opening. The temporary surface installation and

maintenance shall be the responsibility of the Permittee until the permanent surface is completed and accepted. It shall be either a hot mix or cold mix asphalt paving material. Temporary surfaces shall be compacted, rolled smooth, and sealed to prevent degradation of the repair and existing structures during the temporary period. Permanent patching shall occur within two (2) weeks except as outlined by the MPW in the Permit.

D.6.3 Pavement Patches

All permanent pavement patches and repairs shall be made with "in kind" materials. For example, concrete patches in concrete surfaces, full depth asphalt patches with full depth asphalt, concrete pavement with asphalt overlay patches will be expected in permanent "overlaid" concrete streets, etc. In no case is there to be an asphalt patch in concrete streets or concrete patch in asphalt streets. Any repair not meeting these requirements will be removed and replaced by the contractor at no expense to MPW.

D.6.4 Removal and Replacement of Unsatisfactory Work

Removal and replacement of unsatisfactory work shall be completed within fifteen (15) days of written notification of the deficiency unless deemed an emergency requiring immediate action. In the event the replacement work has not been completed, MPW will take action upon the contractor's bond to cover all related costs.

D.6.5 Warranty for Satisfactory Work

The utility company will be held responsible for a 24-month period for any defects in the patch that may result in a PCI of 85 or less as defined by ASTM D6433 as modified for this study.

D.7 REMOVALS

D.7.1 Paved Streets

Bituminous pavement removal areas shall be saw cut to clean, straight lines that are perpendicular or parallel to the flow of traffic.

In existing pavement, all excavations within 36 inches of the edge of the asphalt shall require removal and replacement from the edge of asphalt to the excavation edge.

Concrete pavement, driveways, streets, and alleys shall be removed to neatly sawed edges cut to full depth.

D.7.2 Gravel Streets

When trenches are excavated in streets or alleys that have only a gravel surface, the contractor shall replace such surfacing on a satisfactory compacted backfill with gravel conforming to MPW specification aggregate base course. Gravel replacement shall be one (1) inch greater in depth to that which originally existed, but not less than four (4) inches. The surface shall conform to the original street grade. Where the completed surface settles, additional gravel base shall be placed and compacted by the Contractor within fourteen (14) days after being notified by MPW, to restore the roadbed surface to finished grade.

Some streets may have been treated with a special surface treatment to control dust and/or bind the aggregates together. In these cases, the Contractor is responsible for installing the gravel surface in the same manner as what was existing. Such surface treatments shall be of

the same chemical composition as what existed prior to the excavation work. MPW shall note on the permit the surface treatment that will be required.

D.7.3 Concrete Curb, Gutter and Sidewalk

Concrete shall be removed to neatly sawed edges to full depth for sidewalks and curb and gutter and shall be saw-cut in straight lines either parallel to the curb or perpendicular to the alignment of the sidewalk or curb. Any removal shall be done to the nearest joint. Replaced sections may require doweling connections if required by MPW.

D.8 BACKFILL

D.8.1 Flowable-Fill

Flowable-fill may be used as utility trench backfill for all trenches unless otherwise specified by MPW. This requirement applies to all pavement and gravel locations. Compaction will be as specified by MPW.

The recommended mix for flowable-fill is shown below. Concrete backfill will not be allowed within the public right-of-way. Flash-fill may be used if approved by MPW. Refer to the appropriate MPW specification.

Table D.1. Recommended flowable-fill mix design.

INGREDIENTS	POUNDS/CUBIC YARD
Cement	42 (0.47 sack)
Water	235 (39 gallons or as needed)
Coarse Aggregate (Size No. 57)	1700
Sand (ASTM C-33)	1845

The maximum desired 28-day strength is 60 psi. The above combination of material, or an equivalent, may be used to obtain the desired "flowable-fill".

Flowable-fill or flash-fill shall be prohibited as a temporary or permanent street surface. Trenches shall initially be backfilled to the level of the original surface. After the flowable-fill has cured, the top surface of the flowable-fill shall be removed and the temporary or permanent surface shall be placed.

Bridging and cutback requirements as described in these standards may still be required if the street failures indicate a clear need.

Repair of failed trenches will be the responsibility of the party requiring the trench.

D.8.2 Conventional Backfill (Other Than Flowable-Fill)

When "non flowable-fill" backfill material has been pre-approved by MPW, backfill in existing or proposed streets, curbs, gutters, sidewalks and alleys is divided into three (3) categories: initial, intermediate and final lifts as defined below:

- The INITIAL LIFT, comprised of washed, clean gravel material, consists of the section from the bottom of the excavation to a point six to twelve (6 - 12) inches above the top of the installation. Placement and compaction of the initial layer shall be as specified by the utility company to protect their installation.

- The INTERMEDIATE LIFT, generally comprised of #67 crushed stone, consists of the section above the initial layer to a point within six (6) inches of the ground level or the bottom of the pavement section, whichever is greater.
- The FINAL LIFT includes both road base and asphalt surfacing. Road base material shall meet MPW specification for aggregate base course or as specified by MPW. Maximum dry density of all soil types used will be determined in accordance with AASHTO T 99 or AASHTO T 180. These densities will be determined prior to placement of backfill.

D.9 RESTORATION

D.9.1 Bore Holes - Vertical and Horizontal

For openings less than or equal to 6 inches in diameter, bore holes shall be filled with patching material (cold mix is not acceptable) to prevent entry of moisture. Patching material used shall be in all cases compatible with the existing surface. Subgrade shall be replaced with flowable fill to provide necessary support to the surface. The sealing of bore holes is the responsibility of the contractor or persons making the bore. For openings greater than 6 inches in diameter, the limits of repair shall be identified in the permit. The completed job shall be flush with the surrounding pavement and have no indentations, pockets, or recesses that may trap and hold water.

D.9.2 Subgrade

The subgrade for the pavement structure shall be graded to conform to the cross sections and profile required by the construction plans. Prior to the placement of aggregate base course or sub-course, the subgrade should be properly prepared. The subgrade should be scarified to a minimum depth of six (6) inches, moisture adjusted as necessary, and recompact.

Prior to approval to place the base or sub-base course, all utility main and service trenches shall be compacted. The density requirement also applies to all utility trenches within the public rights-of-way from a point four (4) feet beyond the edge of asphalt and descending at 1:1 outward.

D.9.3 Asphalt Surfacing

Any damage, even superficial, to the existing asphalt surface in the vicinity of the work shall be repaired at the expense of the Contractor, including but not limited to gouges, scrapes, outrigger marks, backhoe bucket marks, etc. A slurry seal type covering will be considered the minimum repair. Patching may be required, at the discretion of MPW.

The depth of asphalt patches in asphalt streets shall typically be the depth of the existing asphalt surface plus 1 inch or as specified by the Engineer.

The asphalt patch area for street excavations that fall within the wheel path of the vehicular travel lane shall be increased in size to the center of the lane or adjacent lane. In no circumstance will the edge of a patch area be allowed to fall within the wheel path.

In streets that are less than five (5) years old or have a PCI greater than 85, the MPW reserves the right to deny any street excavation or require repairs that are over and above these specifications.

D.9.4 Concrete Surfacing and Patching

The concrete pavement shall be replaced with 4,000 psi concrete to match the finish and thickness of the existing pavement, but not less than eight (8) inches thick. All concrete construction shall be protected from vehicular traffic, including contractor vehicles, until the concrete has achieved eighty (80) percent of its ultimate strength. Concrete shall be coated and sealed with a uniform application of membrane curing compound applied in accordance with manufacturer's recommendations.

The use of quick-curing concrete (3000 psi strength within 48 hours) shall be used on all arterial and collector streets when repair areas are less than 500 square feet or when temperatures are below 40° F. Quick-curing concrete repairs may be opened to traffic within two (2) days or when the concrete has achieved eighty (80) percent of its ultimate strength.

Where existing cracks or damage is adjacent to the area being repaired, the repair area shall include the cracked or damaged concrete. Pavement repairs shall include all areas of damage, including leak test holes, pot holes, equipment, and/or material scarring of the exiting surface.

When repairing concrete, removal perimeter shall be saw-cut, and replacement concrete shall be doweled into the old concrete as directed by MPW.

D.10 IMPLEMENTATION

The community investment in streets and roads is a major component of the community assets. As custodians of these facilities, MPW has the obligation and responsibility to protect the public interest.

Presented herein have been concepts and examples that can easily be incorporated into MPW specifications. These examples provide a cost-effective approach to achieve quality repairs of utility cuts that will satisfy the public motorists and achieve levels of service meeting the expectations of MPW.